

PARTS LIST			
ITEM	PART #	DESCRIPTION	NOTES
1	K1936	2Part 6in Double Face Body	Assembly
2	K1940/55/44	2Part Ext. Retainer/ 2Part Ext. Frame/ 2Part Retainer	Assembly
24	5290	2Part Retainer Screw	Pre-drill 1/8" pilot holes
25	5290	2Part Ext. Retainer Screw	Pre-drill 1/8" pilot hoels

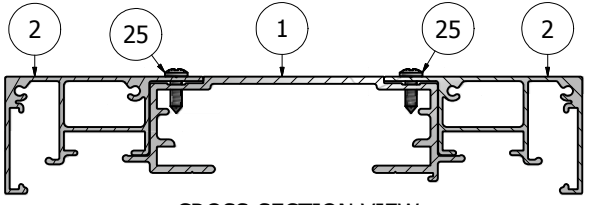

CROSS-SECTION VIEW

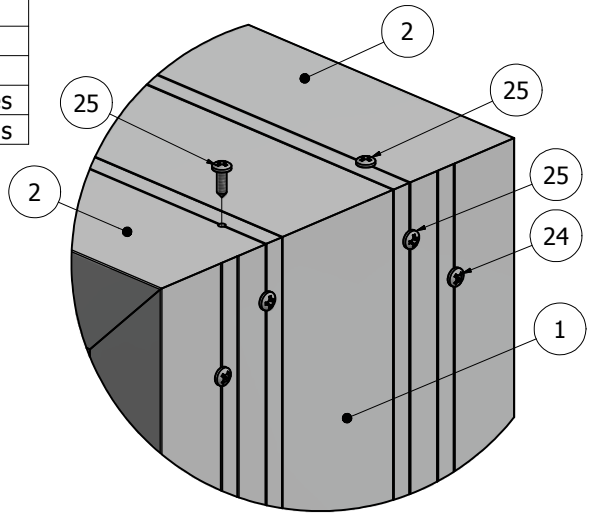

DETAIL B

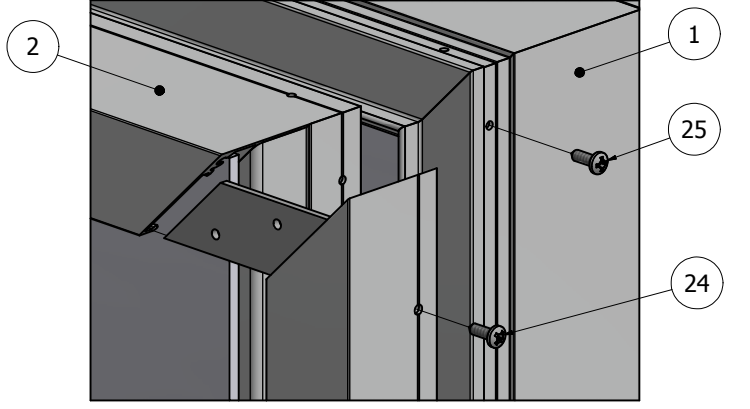
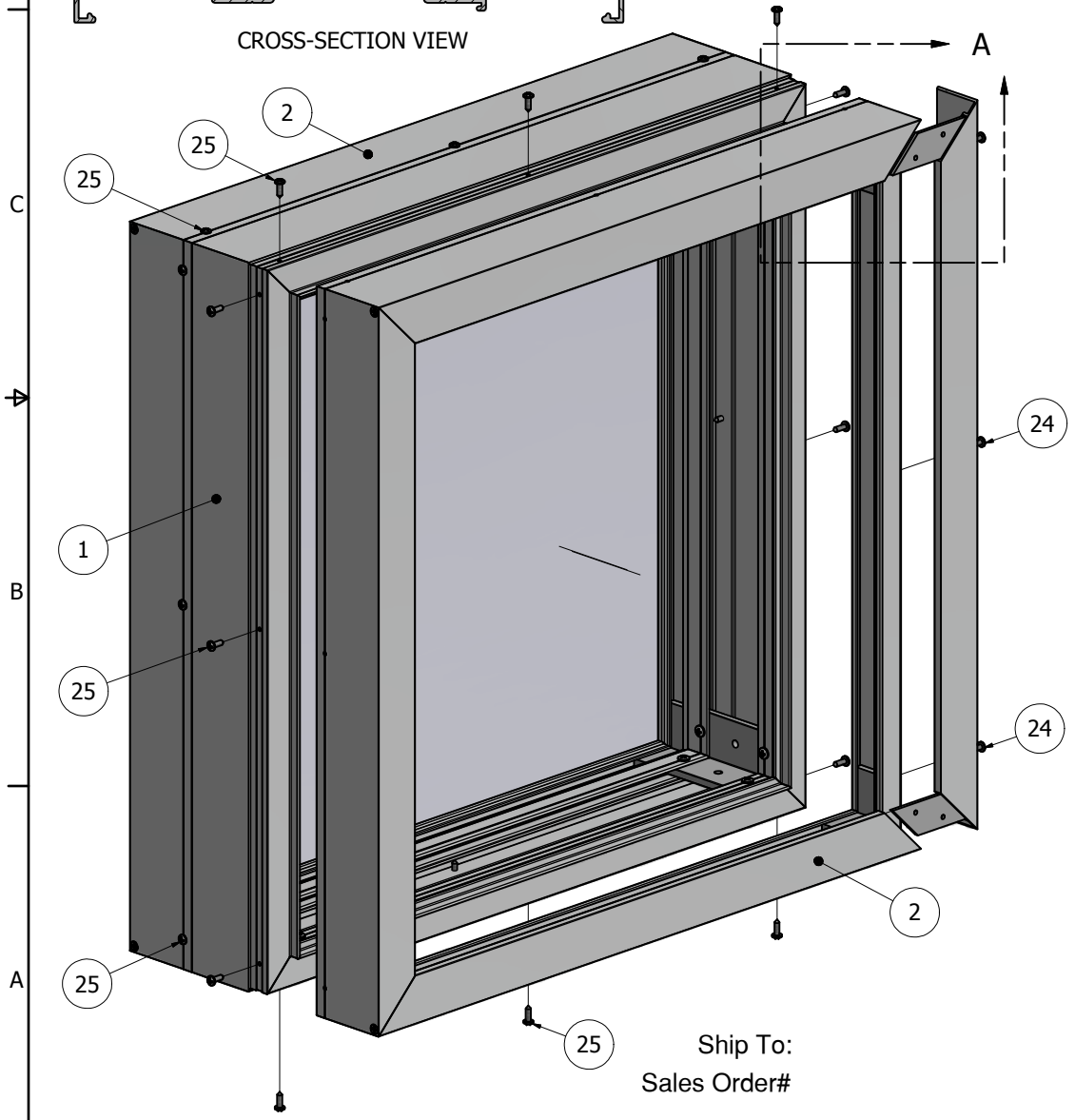
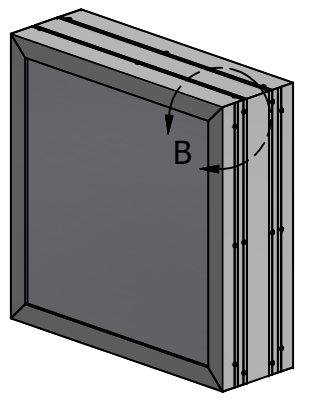

DETAIL A

NOTE: PRE-CUT KITS ARE NOT PRE-DRILLED.
 (Holes shown in this drawing are for reference only.
 Drilling of pilot holes are to be done by fabricator.)

THIS DRAWING WAS CREATED AT NO CHARGE TO ASSIST YOU IN VISUALIZING OUR PROPOSAL. THE DRAWING HEREIN IS THE PROPERTY OF SIGNCOMP. PERMISSION TO COPY OR REVISE THIS DRAWING OR TO USE THIS DRAWING FOR PRODUCTION IS STRICTLY PROHIBITED AND CAN ONLY BE COPIED, REVISED OR USED FOR PRODUCTION WITH THE EXPRESSED WRITTEN PERMISSION OF SIGNCOMP.

DRAWING BY:	SBreihof	1/17/2014
Centroid X:	0.000 in	
Centroid Y:	0.000 in	
Principal Moments Ix:	0.000 in ⁴	
Principal Moments Iy:	0.000 in ⁴	
Section Modulus Ix:	0.000 in ³	
Section Modulus Iy:	0.000 in ³	

<h1>SignComp</h1>		TITLE
		2Part 6in Double Face Body w/ 2Part Extended Retainer - Assembly
PART NO	K1936/40	REV
		SHEET 1 OF 1

Ship To:
Sales Order#

PARTS LIST			
ITEM	PART #	DESCRIPTION	NOTES
1	1936	2Part 6in Double Face Body	Top & Bottom
2	1936	2Part 6in Double Face Body	Sides
3	5985	1Part 2Part 6in Body Corner Angle	
13	5218	Corner Angle Screw	Drill 5/32" pilot hole

NOTE: ANGLE HARDWARE MAY BE WELDED OR MECHANICALLY FASTENED AS SHOWN.

Ship To:
Sales Order#

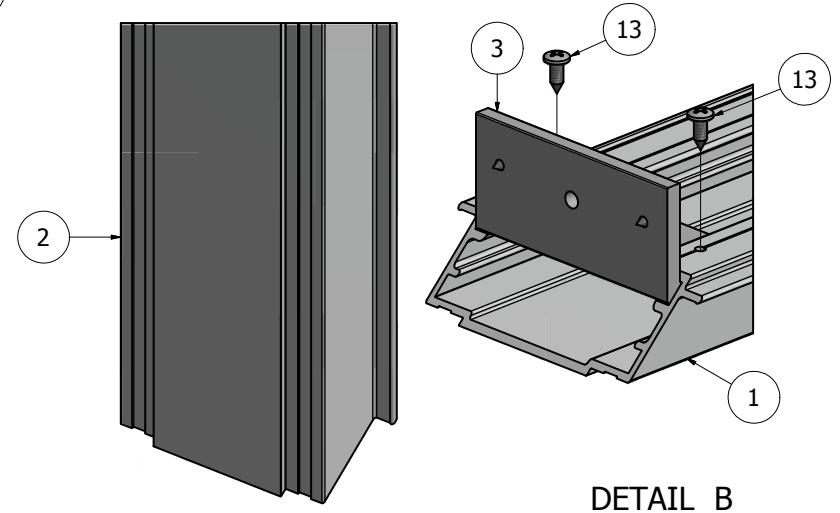
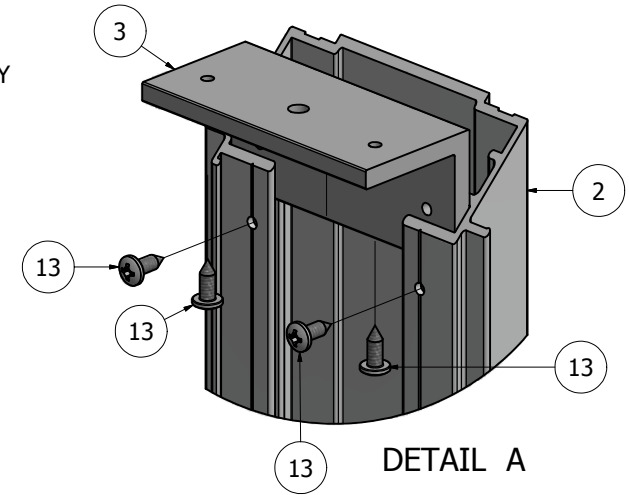
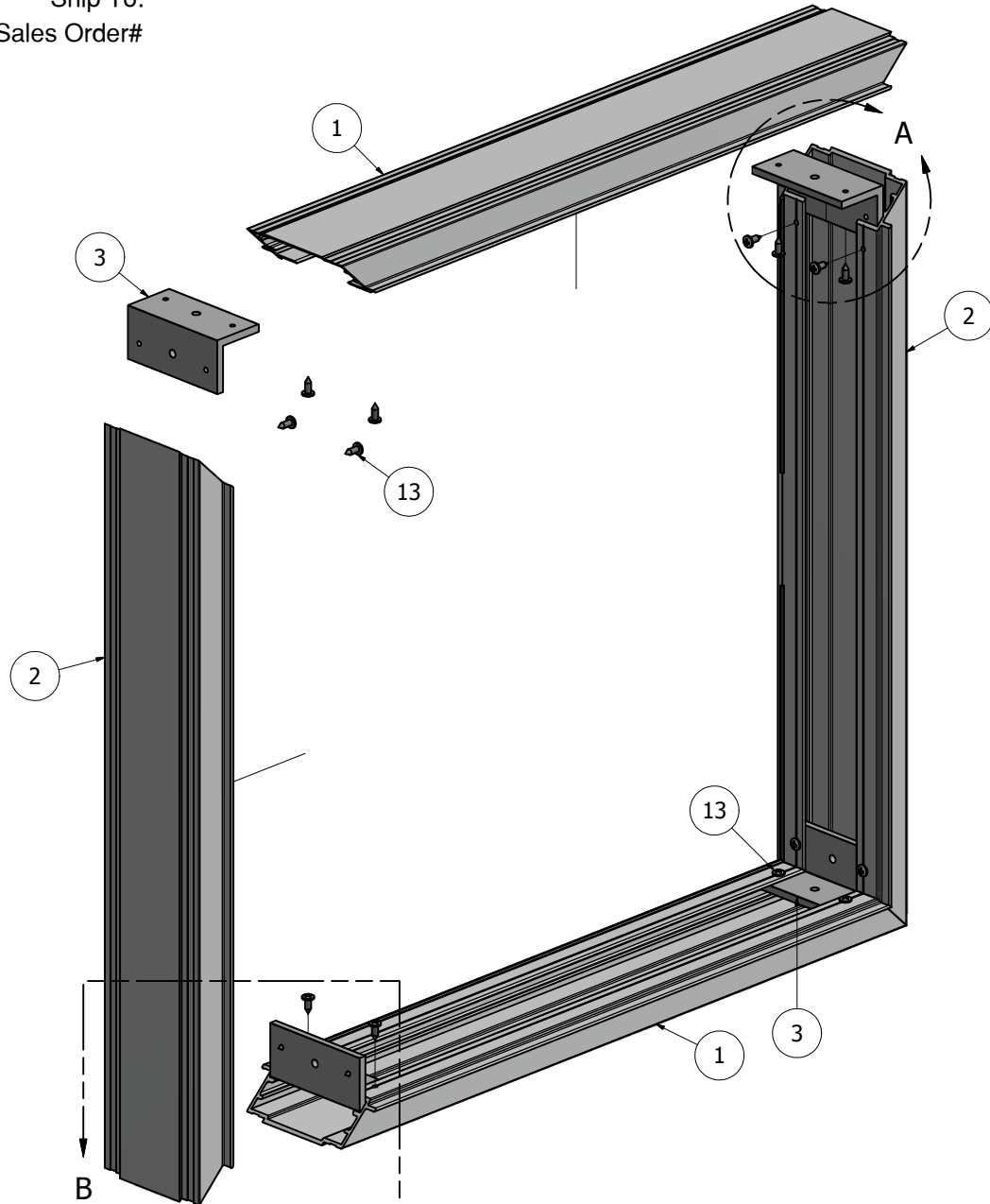

NOTE: PRE-CUT KITS ARE NOT PRE-DRILLED.
(Holes shown in this drawing are for reference only.
Drilling of pilot holes are to be done by fabricator.)

THIS DRAWING WAS CREATED AT NO CHARGE TO ASSIST YOU IN VISUALIZING OUR PROPOSAL. THE DRAWING HEREIN IS THE PROPERTY OF SIGNCOMP. PERMISSION TO COPY OR REVISE THIS DRAWING OR TO USE THIS DRAWING FOR PRODUCTION IS STRICTLY PROHIBITED AND CAN ONLY BE COPIED, REVISED OR USED FOR PRODUCTION WITH THE EXPRESSED WRITTEN PERMISSION OF SIGNCOMP.

DRAWING BY:	SBreihof	12/6/2013
Centroid X:	0.000 in	
Centroid Y:	0.000 in	
Principal Moments Ix:	0.000 in ⁴	
Principal Moments Iy:	0.000 in ⁴	
Section Modulus Ix:	0.000 in ³	
Section Modulus Iy:	0.000 in ³	

SignComp

TITLE
2Part 6in Double Face Body - Assembly

PART NO
K1936

REV

PARTS LIST			
ITE	PART	DESCRIPTION	NOTES
1	1940	2Part Extended Retainer	Top, Bottom & One Side
2	1955	2Part Extended Frame	One Side
3	1944	2Part Retainer	One Side
4	5210	Corner Key	
5	5305	Frame Corner Angle	
24	5290	2Part Retainer Screw	Drill 1/8" pilot hole
28	5241	2Part Extended Retainer Corner Screw	See Detail B

Ship To:
Sales Order#:

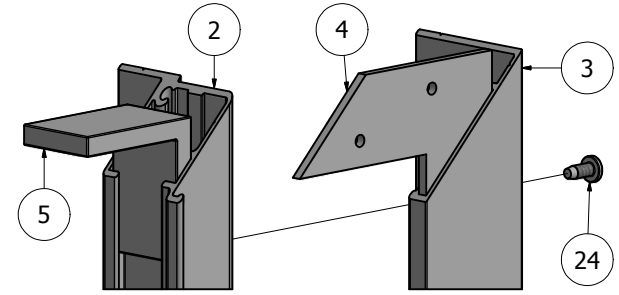

DETAIL A-1

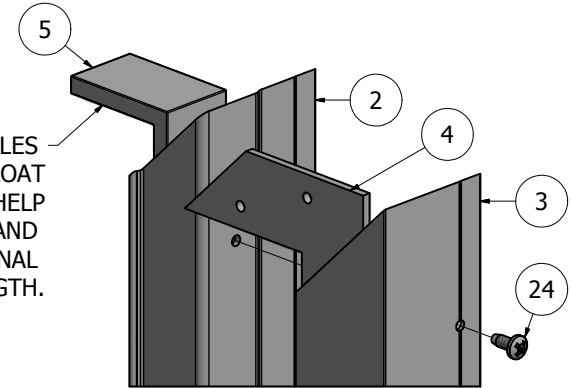

DETAIL A-2

FRAME CORNER ANGLES AND CORNER KEYS FLOAT IN THE EXTRUSION TO HELP ALIGN THE MITRES AND PROVIDE ADDITIONAL STRENGTH.

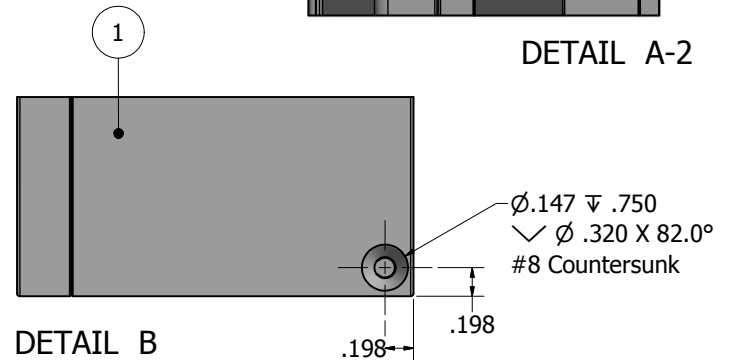

DETAIL B

NOTE: PRE-CUT KITS ARE NOT PRE-DRILLED.
(Holes shown in this drawing are for reference only. Drilling of pilot holes are to be done by fabricator.)

THIS DRAWING WAS CREATED AT NO CHARGE TO ASSIST YOU IN VISUALIZING OUR PROPOSAL. THE DRAWING HEREIN IS THE PROPERTY OF SIGNCOMP. PERMISSION TO COPY OR REVISE THIS DRAWING OR TO USE THIS DRAWING FOR PRODUCTION IS STRICTLY PROHIBITED AND CAN ONLY BE COPIED, REVISED OR USED FOR PRODUCTION WITH THE EXPRESSED WRITTEN PERMISSION OF SIGNCOMP.

DRAWN	SBreihof	7/19/2012
Centroid X:	0.000 in	
Centroid Y:	0.000 in	
Principal Moments Ix:	0.000 in^4	
Principal Moments Iy:	0.000 in^4	
Section Modulus Ix:	0.000 in^3	
Section Modulus Iy:	0.000 in^3	

SignComp		TITLE
		2Part Extended Retainer
DWG NO	K1940/55/44	REV
SHEET 1 OF 1		

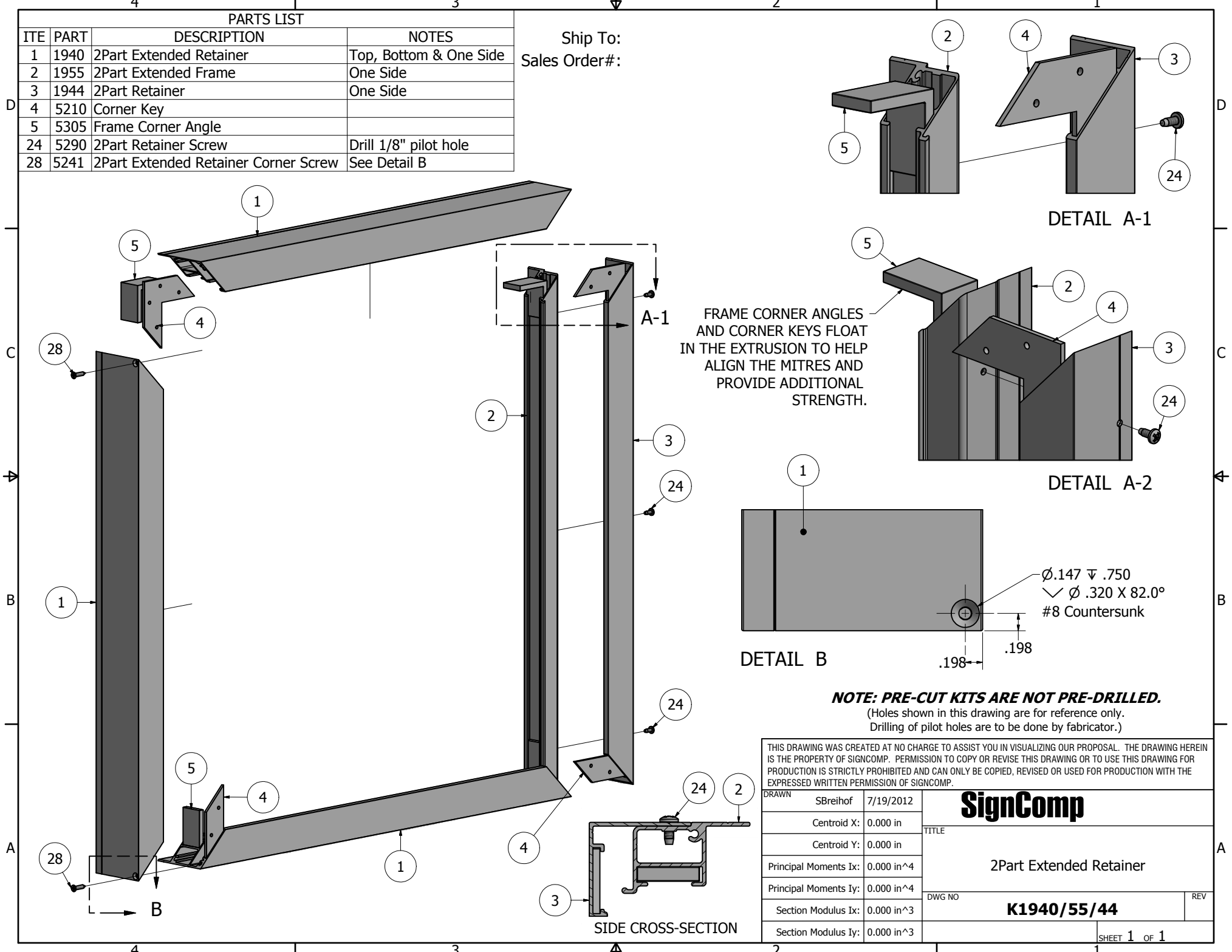

SIDE CROSS-SECTION